



Service Info



Problems changing gear after clutch replacement

The clutch actuator push rod must be adjusted after repair

Manufacturer: Iveco

Models: Stralis AT/AD
Engrenagem Eurotronic Automated

In the vehicles listed above, the slave cylinder is fitted with a device which automatically compensates for facing wear of the clutch disc.

For this reason, the slave cylinder push rod must be adjusted precisely when the clutch and/or the clutch actuator is replaced.

Procedure:

- For a removed actuator, move the clutch lever in the direction of the clutch until the idle length is cancelled out
- Measure distance A between the deepest point of the ball socket of the clutch lever and the back face of the clutch actuator
- Completely remove the push rod from the clutch actuator
- Unscrew the bleeder screw from the slave cylinder so that the spring in the cylinder can push the piston forward until it reaches the stop

Measure distance B between the back face of the clutch actuator and the front edge of the pressure sleeve. Also measure distance C, which is the depth of the conical pressure sleeve of the piston.

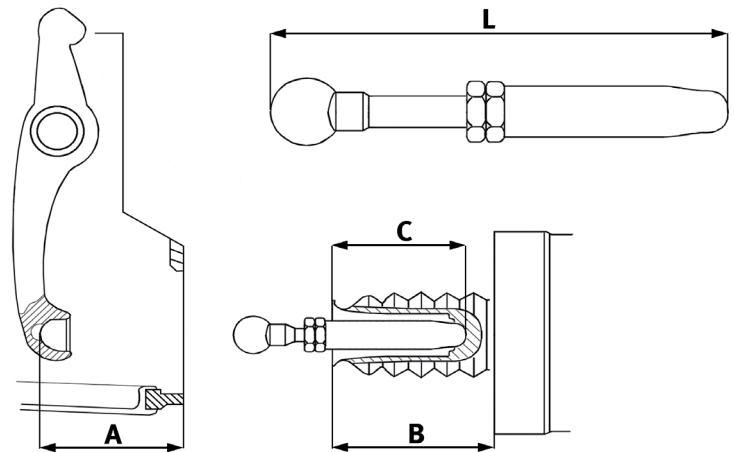

Image 1: The dimensions of the push rod can be calculated with the measured values

The length (L) of the push rod is then calculated with the following formula:

$$L = A - B + C + D$$

A, B and C here are measured values. The measurement D describes the value for the greatest stroke of the clutch actuator, which is 33 mm. If the measured value deviates from this, the ball head and the push rod must be twisted by loosening the nut on the push rod until the required length is reached. The nut on the push rod must subsequently be tightened with 52 Nm and inserted into the clutch actuator.

Please observe the vehicle manufacturer specifications!

You want more? We can help!

Phone: +44 (0) 1432 264 264*

Fax: +44 (0) 1432 375 760

hfd-info@schaeffler.com

www.schaeffler-aftermarket.co.uk

* Calls from within the UK 08457 001100

